



# Technical Data

# fino collection TOILET ROLL HOLDER

# B-9543

### Specify Finish Required

- Stainless Steel, Satin Finish
- Matte Black Finish, please use model no. B-9543.MBLK

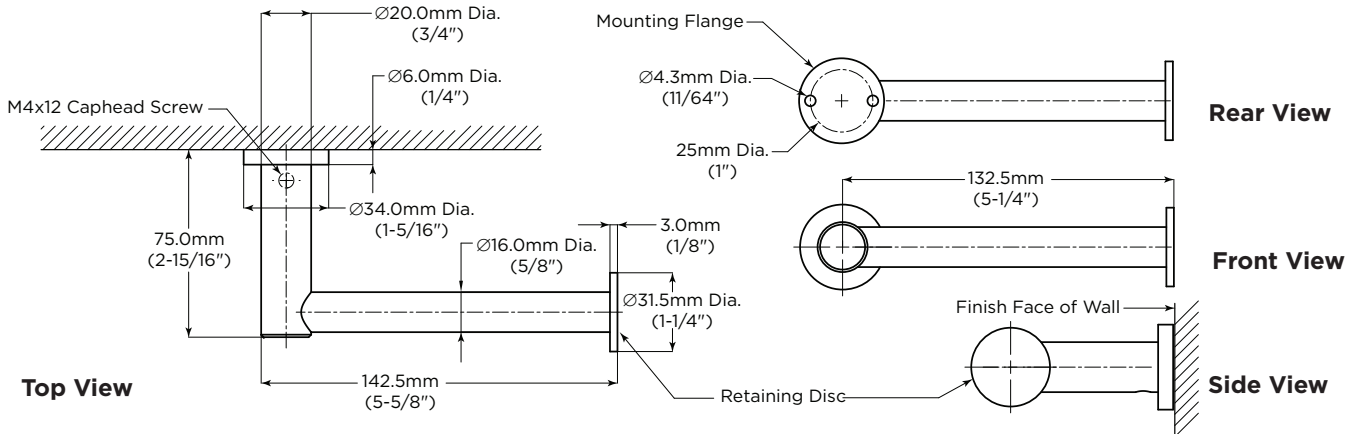

### MATERIAL:

**Post** — Type 303, 20mm (3/4") diameter machined stainless steel bar with satin finish, fastened to the Mounting Flange with a set screw by securing the Flange Cover.

**Dispenser Bar** — Type 303, 16mm (5/8") machined stainless steel bar with satin finish, permanently connected to the post, allowing for right or left handed assembly.

**Retaining Disc** — Type 303, 31.5mm diameter, 3mm (1/8") thick stainless steel disc, permanently attached to the Dispenser Bar.

**Concealed Mounting Flange** — Type 303, 34mm (1-5/16") diameter, 4mm (5/32") thick stainless steel with satin finish with two holes for attachment to wall.

**Flange Cover** — Type 303, 34mm diameter, 2mm (1/16") thick stainless steel with satin finish, secured to Mounting Flange by the Post to conceal mounting screws.

**5-Year Limited Warranty** — In addition to Bobrick's one-year guarantee, Bobrick extends a limited 5-year warranty from the date of purchase on all parts for model B-9543. This warranty is limited to the repair or exchange of defective parts at the option of Bobrick and is only extended to the original owner of the installed unit against defects in factory workmanship or material under normal use and service.

### INSTALLATION:

For plaster or dry wall construction, provide concealed backing to comply with local building codes, then secure unit with sheet-metal screws (not furnished). For other wall surfaces, provide fiber plugs or expansion shields for use with sheet-metal screws (not furnished), or provide 3mm (1/8") toggle bolts or expansion bolts.

For partitions with particle-board or other solid core, secure with sheet-metal screws (not furnished), or provide through-bolts, nuts, and washers. For hollow-core metal partitions, provide solid backing into which the sheet-metal screws (not furnished) can be secured.

### SPECIFICATION:

Toilet Roll Holder shall be type 303 machined stainless steel in satin finish. Double Toilet Tissue Dispenser shall have 20mm (3/4") diameter machined post with integrated 16mm (5/8") diameter machined Dispenser Bar. Retaining Discs shall be type 303, 31.5mm (1-1/4") diameter, 3mm (1/8") thick stainless steel with satin finish permanently connected to Dispenser Bar. Concealed mounting flange shall be 4mm (5/32") thick threaded solid stainless steel plate, 34mm (1-5/16") diameter and equipped with two screw holes for attachment. Threaded solid flange cover shall be 2mm (1/16") thick stainless steel in satin finish, 34mm (1-5/16") diameter. Set screw shall fasten the post to the flange and secures the flange cover

**Toilet Roll Holder shall be Model B-9543 of Bobrick Washroom Equipment, Inc., Clifton Park, New York; Jackson, Tennessee; Los Angeles, California; Bobrick Washroom Equipment Company, Scarborough, Ontario; Bobrick Washroom Equipment Pty. Ltd., Australia; and Bobrick Washroom Equipment Limited, United Kingdom.**