

NSU 11 Touchless

Touchless dispenser for disinfectant (D), foam soaps (F) and liquid soaps (S), stainless steel (AFP) or powder-coated, 1200 ml

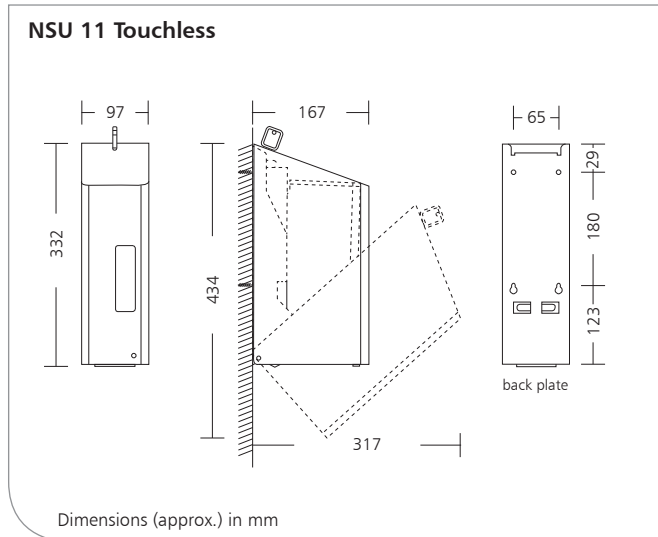

Product characteristics

- ▶ Touchless dispenser for dosing liquid soaps and disinfectants (S), low-viscosity hand disinfectants with spray pump (D) or foam soap (F)
- ▶ Refillable soap dispenser with 1200 ml volume plus overflow quantity
- ▶ Housing with sloped lid to prevent foreign objects being placed on the dispenser
- ▶ High-quality and robust stainless steel housing
- ▶ Plastic lock with anti-vandalism function
- ▶ Modular system with replaceable container/pump unit, for liquid soaps and disinfectants (S), low-viscosity hand disinfectants with spray pump (D) or foam soap (F)
- ▶ Dispensing quantity ca. 0.7 ml/stroke (D spray pump), ca. 0.7 ml/stroke (F foam pump), ca. 1.5 ml/stroke (S lotion pump)
- ▶ Easily filled from above
- ▶ Open without wall contact
- ▶ Container easily removed for cleaning
- ▶ Viewing window to check fill level
- ▶ Incl. mounting kit for four-point wall mounting

Interesting information

- References:
- ▶ Conference centres, exhibitions, airports, train stations, catering, retirement/care homes, hospitals, laboratories, commercial kitchen, food processing, industry, shopping centres, hotels, correctional facilities, schools, kindergartens, sports centres, administration facilities

Application examples:

- ▶ Washrooms, toilets, baths, care and examination rooms, kitchens, production facilities, entrance areas, transit areas

Technical data

- Housing: Stainless steel AISI 304, brushed with Anti-Fingerprint-Coating (AFP), powder-coated white (RAL 9010) or powder-coated matte black (RAL 9005)
- Viewing window: Transparent plastic
- Dosing pump: For liquid soaps and disinfectants (S), low-viscosity hand disinfectants with spray pump (D) or foam soap (F), dispensing quantity ca. 0.7 (D) – 0.7 (F) – 1.5 (S) ml/stroke
- Lock: Vandalism-proof lock, plastic
- Wall mounting: Wall mounting with 4 screws and wall plugs recommended installation height 20 cm above the washbasin
- Weight: 2,9 kg

Description for tender - see overleaf

NSU 11 Touchless/0121/2.0



Subject to technical modifications.
Product compatibility testing required before new filling materials are used!



OPHARDT HYGIENE-TECHNIK GmbH + Co. KG
Lindenau 27 | 47661 Issum | Germany
Tel.: +49 (0) 28 35 18-10 | Fax +49 (0) 28 35 18-77
planer@ophardt.com | www.ophardt.com

NSU 11 Touchless

Touchless dispenser for disinfectant (D), foam soaps (F) and liquid soaps (S), stainless steel (AFP) or powder-coated, 1200 ml

Description for tender

... Pcs. **SanTRAL® Classic NSU 11 Touchless E/S Steel Touch (ST) Art. No. 1419395**
Touchless dispenser for liquid soaps and disinfectant, 1200 ml, brushed stainless steel housing with OPHARDT Hygiene Anti-Fingerprint-Coating (AFP), stainless steel back plate, incl. 4 alkaline "D" batteries, proximity sensor, with vandalism-proof lock, viewing window for monitoring filling level, removable refillable container, free choice of manufacturers for refill materials, housing with sloped lid to prevent foreign objects being placed on the dispenser
Dimensions: W 97 x H 332 x D 167 mm

... Pcs. **SanTRAL® Classic NSU 11 Touchless E/F Steel Touch (ST) Art. No. 1419397**
Touchless dispenser for foam soaps, 1200 ml, brushed stainless steel housing with OPHARDT Hygiene Anti-Fingerprint-Coating (AFP), stainless steel back plate, incl. 4 alkaline "D" batteries, proximity sensor, with vandalism-proof lock, viewing window for monitoring filling level, removable refillable container, free choice of manufacturers for refill materials, housing with sloped lid to prevent foreign objects being placed on the dispenser
Dimensions: W 97 x H 332 x D 167 mm

... Pcs. **SanTRAL® Classic NSU 11 Touchless E/D Steel Touch (ST) Art. No. 1419396**
Touchless dispenser for disinfectant with spray pump, 1200 ml, brushed stainless steel housing with OPHARDT Hygiene Anti-Fingerprint-Coating (AFP), stainless steel back plate, incl. 4 alkaline "D" batteries, proximity sensor, with vandalism-proof lock, viewing window for monitoring filling level, removable refillable container, free choice of manufacturers for refill materials, housing with sloped lid to prevent foreign objects being placed on the dispenser
Dimensions: W 97 x H 332 x D 167 mm

Additional models:

for liquid soaps:

NSU 11 P/S Touchless Ivory White (IW) Art. No. 1419392
NSU 11 P/S Touchless Midnight (MN) Art. No. 1422858

for foam soaps:

NSU 11 P/F Touchless Ivory White (IW) Art. No. 1419394
NSU 11 P/F Touchless Midnight (MN) Art. No. 1422860

with spray pump for dosing of disinfectants:

NSU 11 P/D Touchless Ivory White (IW) Art. No. 1419393
NSU 11 P/D Touchless Midnight (MN) Art. No. 1422861

Additional RAL Classic colours available upon request.

Product: **SanTRAL® Classic**
Manufacturer: OPHARDT HYGIENE-TECHNIK GmbH + Co. KG

Compatible accessories

- ▶ Stainless steel drip tray for mounting with the dispenser (preset distance from the bottom edge)
Art. No. 1420576
Dimensions: W 95 x H 240 x D 183.3 mm
- ▶ Stainless steel drip tray for mounting under the dispenser (distance from the bottom edge can be freely selected, additional mounting holes)
Art. No. 1420575
Dimensions: W 95 x H 30 x D 183.3 mm